

Burial Depth: Recommended max burial depth of 2 metre over top of tank lid away from vehicular travel.
Reinforcing:

Sides / Bottom: Tufstrand fibre reinforcement dosed at 3kg/m3

Top: 10m and 15m rebar longitudinally max 10" ct, 1" cover
10m rebar laterally max 12" ctc 1" cover

Strength: 35 MpA @ 28 DAYS MIN
Air entrainment: 5-8%

Joints: Conseal 102 mastic applied at factory by Roswell Concrete

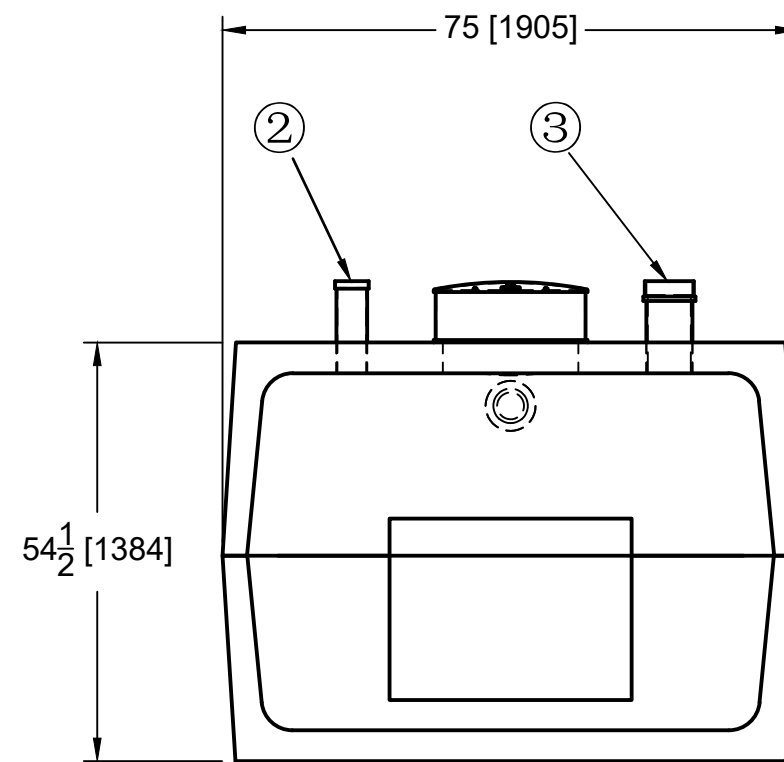
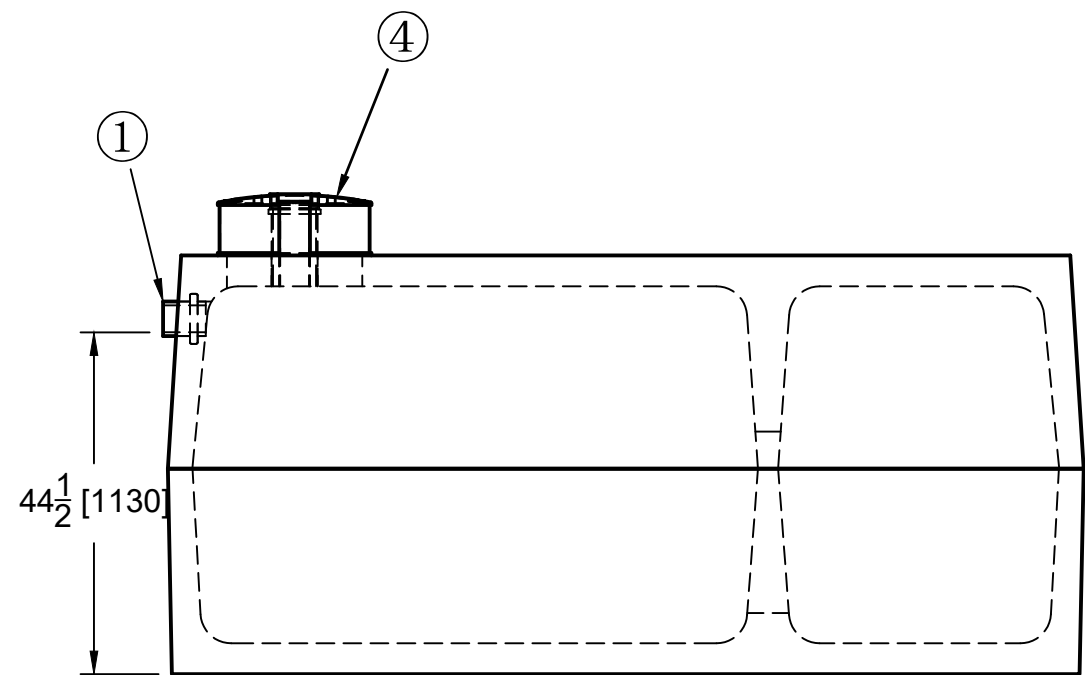

Top Weight
tons
Bottom Weight
tons
Assembled Weight
5.8 tons

**5675L (1250gal)
Holding Tank**

- 1: 4" Inlet rubber
- 2: 4" Coupler with pipe and cap
- 3: 6" Coupler with pipe and cap
- 4: 20" Diameter polylok riser