

Burial Depth: Recommended max burial depth of 2 metre over top of tank lid away from vehicular travel.

Reinforcing:

Sides / Bottom: tufstrand fibre reinforcement dosed at 3kg/m³

Top: 10m and 15m rebar longitudinally max 10" ct, 1" cover
10m rebar laterally max 12" ctc 1" cover

Strength: 35 MpA @ 28 DAYS MIN
Air entrainment: 5-8%

Joints: Conseal 665 mastic applied at factory by Roswell Concrete

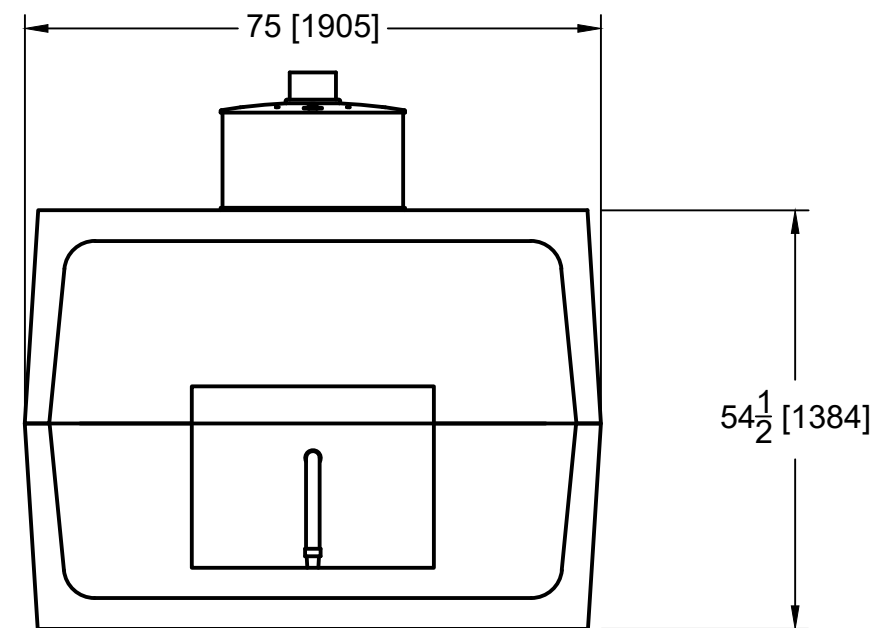
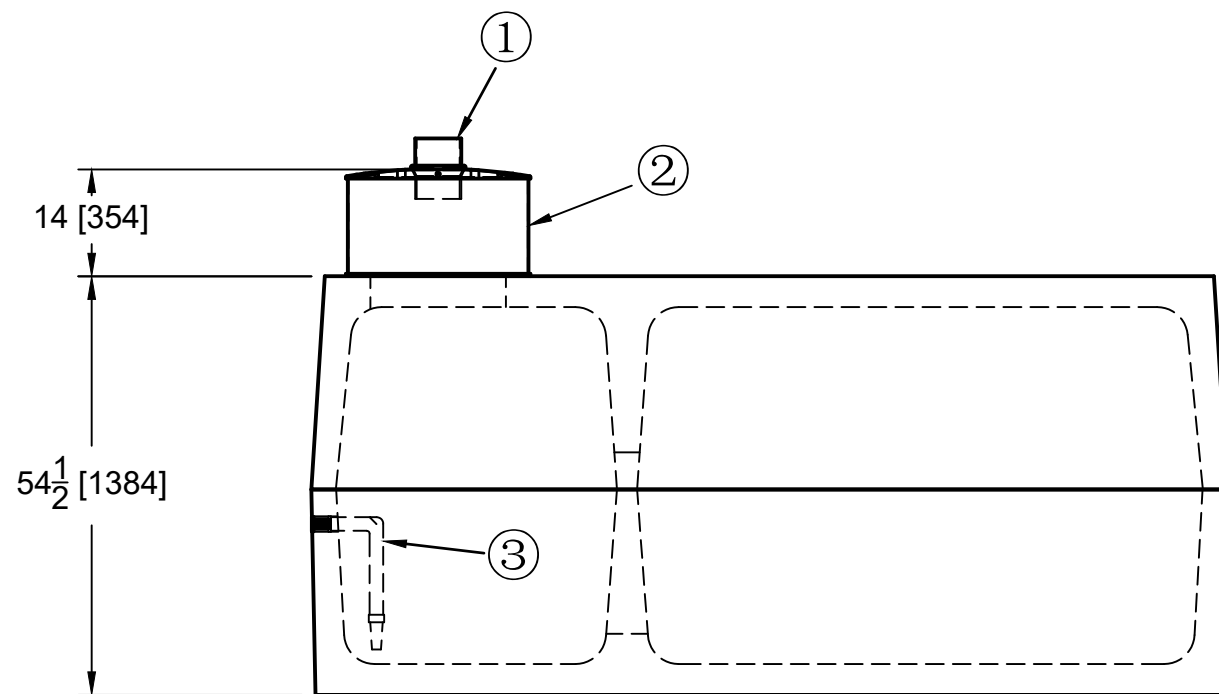

Top Weight
tons
Bottom Weight
tons
Assembled Weight
5.8 tons

5700L (1250gal)
Cistern

- 1: 6" PVC fill stack with removable cap
- 2: 24" x12" high Polylok acces with gasket
- 3: 1-1/4" stainless steel coupler with footvalve pre-installed in tank