

Burial Depth: Recommended max burial depth of 2 metre over top of tank lid away from vehicular travel.  
Reinforcing:

Sides / Bottom: tufstrand fibre reinforcement dosed at 3kg/m<sup>3</sup>

Top: 10m and 15m rebar longitudinally max 10" ct, 1" cover  
10m rebar laterally max 12" ctc 1" cover

Strength: 35 MpA @ 28 DAYS MIN  
Air entrainment: 5-8%

Joints: Conseal 102 mastic applied at factory by Roswell Concrete

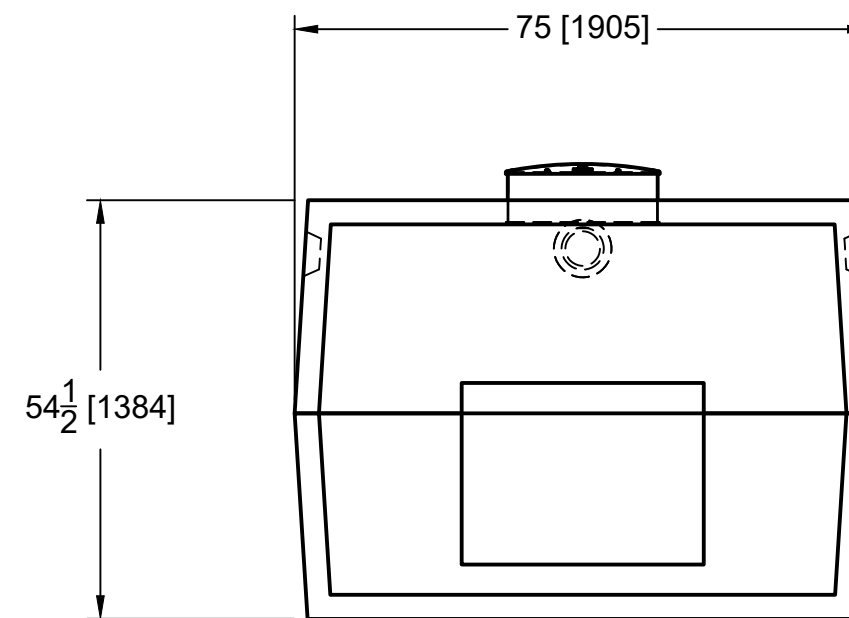
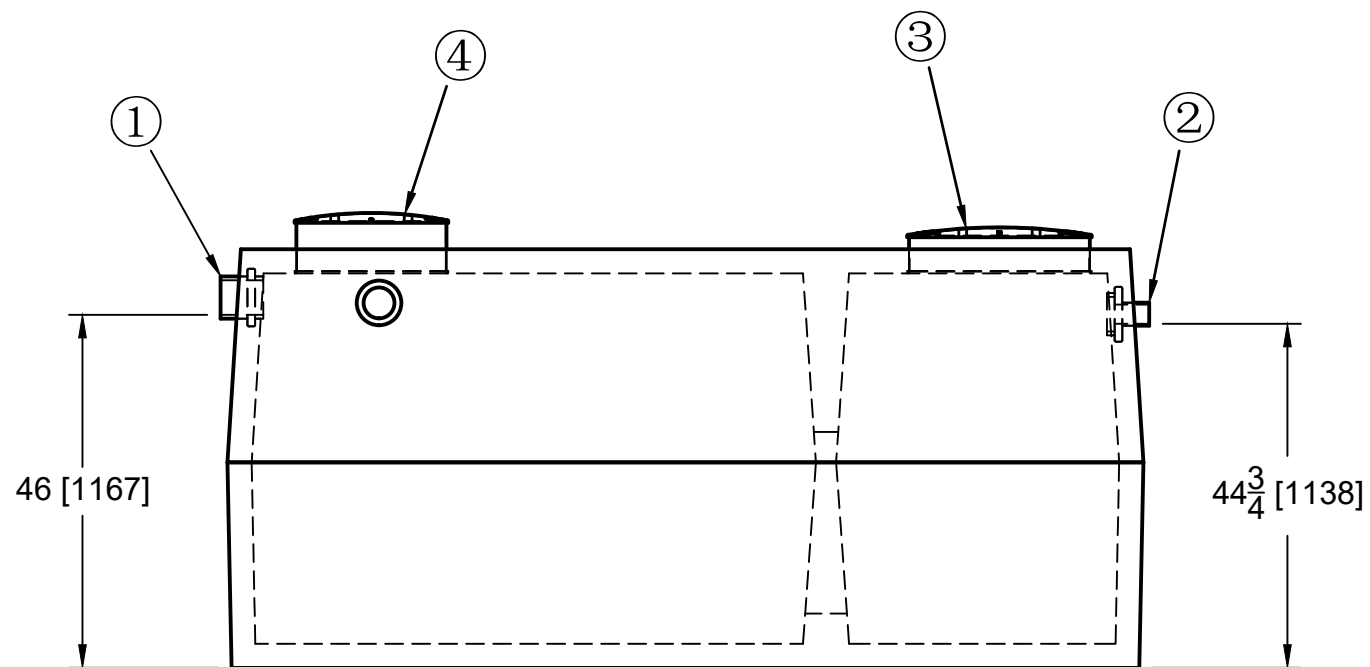

- 1: 4" Inlet rubber
- 2: 2" Outlet rubber
- 3: 24" Diameter polylok riser
- 4: 20" Diameter polylok riser

Top Weight  
2.7 tons

Bottom Weight  
3.1 tons

Assembled Weight  
5.8 tons

**4680L (1035)**  
**Pump Chamber**